

QUADRO H200 COFFEE MATE REVERSE OSMOSIS SYSTEM

FOR THE PERFECT WATER, PERFECT CUP OF COFFEE &
PERFECT COFFEE MACHINE PROTECTION

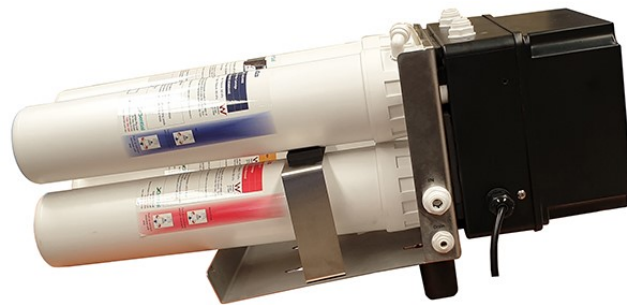

WaterMark
AS 3497
Lic 52017



- All-in-one space saving design
 - Horizontal or wall mount installation
 - Simplified solutions
 - Simplified water filter service
 - Provide more natural water (built in water remineraliser filter)
 - Reduce running cost
 - Specifically designed for use with coffee machines for better tasting coffee
 - Eliminate scale
 - Remove/ reduce chloride
 - Reduce mineral shards or salt
 - Reduce energy consumption
 - Built in water pressure booster pump
 - Built TDS meter
- 

REVERSE OSMOSIS PURIFICATION – PROTECTION

It is important to know that coffee is 99% water and it is the most important element which coffee brewers should consider when making a good quality coffee. If the water used doesn't taste and smell right, then don't use it. QuadRO-H200 Reverse Osmosis (RO) is a water purification technique that reduces the quantity of total dissolved solids (TDS) in water. TDS can affect the taste of water (e.g. salinity). QuadRO-H200 utilise its built pressure pump to push raw wastewater against a special semi-permeable membrane. It is essentially a molecular squeezing process which causes water molecules to separate from the contaminants. The separated clean water molecules then pass through to the inside of the membrane on to a holding reservoir. The contaminants are washed from the membrane and disposed.



QuadRO H200 has been proven to provide total protection for coffee machines as well as produces best water for making coffee for many years.

QuadRO H202 Installation Diagram

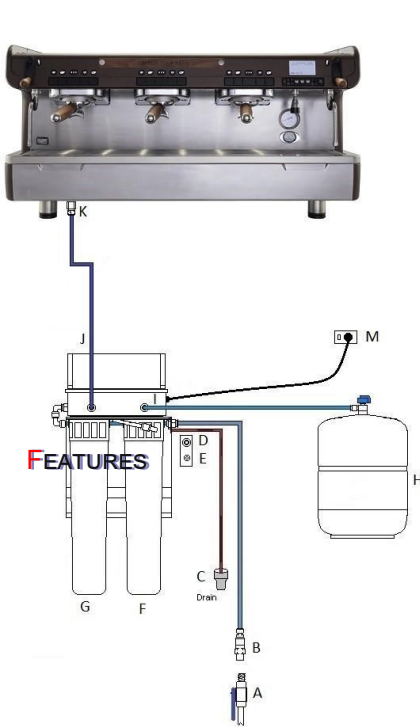

- A: Water supply isolation valve
- B: Multi-function pressure limiting valve
- C: Waste water tundish
- D: Water "IN"
- E: Waste water "Drain"
- F: AX12-ROM membrane
- G: AX12-WS water stabiliser cartridge
- H: RO storage tank
- I: "Tank" connection
- J: Appliance "APP" connection
- K: Coffee machine connection
- L: Combination oven
- M: 10 Amp power plug

PROBLEM AND SOLUTIONS

High Total Dissolve Solid (TDS) in water includes lime-scale and chloride which can result in increased energy usage, rust and costly service and repair.

QuadRO-H200 removes up to 96% of the TDS in the water. High salt rejection membrane is the ideal environment for long term protection of your investment.

- ▶ Compact with stainless steel frame design
- ▶ Snap on fittings and cartridges for quick installation and service.
- ▶ Built water pressure booster pump
- ▶ Water stabiliser mineral filter included. Making the water more natural taste.
- ▶ Scale free water for steaming.
- ▶ Built in TDS meter to monitor the quality of the water
- ▶ Utilises High performance membrane to cater for highly demanding environment.
- ▶ All installation accessories are included.
- ▶ Easy to install with no messy tubing connections.

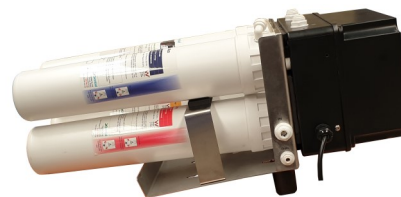

Installation requirement

- 10 amp power point
- Waste water drain
- 15mm water supply with isolation valve

SPECIFICATION

| MODEL | Min-max pressure | OUTPUT (L/ Day) | DIMENSION L x D x H (cm) | TANK CAPACITY Litre (H x Dia cm) | Installation |
|--------------|------------------|-----------------|--------------------------|----------------------------------|---|
| QUADRO-H2019 | 150kPa - 600kPa | 750 | 32 x 28 x 61 | 19 (43 x 26 cm) | Comes with pressure limiting valve, oven fittings, tubes, & installation manual |

Reseller:

Xsential Pty Ltd
 78 Daly Street
 Ascot Western Australia 6104
 Ph: 1300 366 295
www.xsential.com.au